

Bukhara State University

Khamza Eshankulov

***MATHEMATICAL MODEL FOR INFORMATION
MONITORING SYSTEM OF FAT AND OIL
ENTERPRISES***

Introduction

Today, the principles, models, methods and data processing c4.5, Apriori, Em, Adaboost, C algorithms for the design of information monitoring systems for manufacturing enterprises developed and implemented by specialists. In the research work of Mansi Gera and Shivani G methods of development and research of such approaches and the methods of classification, clustering, regression of algorithms were used.

Different systems are used in each field of production. For example, raw material accounting, payroll, document management, production process management, and personnel department systems.

The rapid development of information monitoring systems, reliability, effective use of resources and the ability to access them online and view the analysis, to draw conclusions for decision-making, has further increased the demand for them. These systems contribute to the monitoring of processes in manufacturing enterprises, the preparation of static and dynamic reports, the acquisition of operational information, the rapid operation of the network and the control and management of production processes for employees.

Introduction

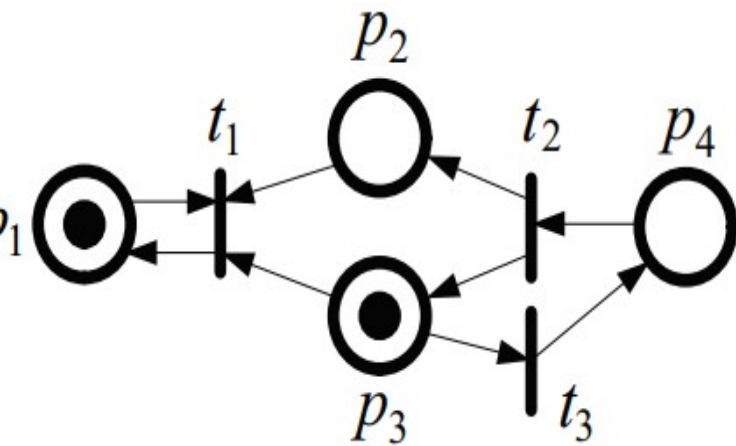

Fig. 1. Petri nets

The Petri nets can be considered as a convenient mathematical method for constructing models of information monitoring systems for multi-stage conveyor-shaped parallel structured production processes.

The Petri nets is a oriented bigraph whose node points are divided into a set of two types (cases and transitions) (Fig. 1). The elements of these sets are connected by mutual arcs.

Materials and methods

The information monitoring system of fat and oil enterprises includes monitoring of every process from the receipt of oilseeds in the production process to its packaging. Production processes are defined by the set $S = \{s_0, s_1, \dots, s_{14}\}$, each $s_i \in S, i = 0, 1, \dots, 14$ element of the set represents a single production process.

In fat and oil enterprises, it is organized in the form of a conveyor through several $S_i = \{s_i^j\} j = 1, \dots, n$ processes. the raw material in the input state to S_i changes to another raw material in the output state after the S_i processes are performed.

The information monitoring system monitors the production processes of the enterprise by monitoring the S_i processes in the enterprise and using $X_i = \{x_1, x_2, \dots, x_n\} \in X$ raw materials entering the process and $s_i : x_i \rightarrow y_i$ outgoing $Y_j = \{y_1, y_2, \dots, y_{n+1}\} \in Y$ data after the process is completed. Production processes are carried out in the workshops of the enterprise $C = \{c_0, c_1, \dots, c_4\}$ [14] (table 1).

Materials and methods

The fat and oil enterprises has the following shops:

- c_0 - taking oily seeds;
- c_1 - preparation and storage of oilseeds;
- c_2 - preparation of oily seeds for oil separation;
- c_3 - oil extraction and refining;
- c_4 - packaging, labeling and storage of oil in the oil depot;

Each shop can cover several production processes $C_i = \{S_k\}, k \in 1 \dots m$ (table 1).

Materials and methods

Table 1. Organization of production processes in fat and oil enterprises at the intersection of shops.

Shop	Fried
<i>c₀</i>	<p>s₀- transfer of oily seeds to the laboratory to determine the quality and quantity</p> <p>s₁- the process of determining the quality indicators and quantity of oilseeds</p>
<i>c₁</i>	<p>s₂- cleaning, sorting and sorting of oily seeds from foreign matter</p> <p>s₃- temporary storage of low-fat seeds of the variety in the warehouse</p> <p>s₄- permanent storage of high-fat seeds of the variety in the warehouse</p>
<i>c₂</i>	<p>s₅- measuring and transferring oily seeds from storage to production</p> <p>s₆- biting oily seeds</p> <p>s₇- breaking down crushed oily seeds into ingredients</p> <p>s₈- transfer the slug to the measuring warehouse</p> <p>s₉- crushing and roasting the separated core</p>
<i>c₃</i>	<p>s₁₀- the process of pressing using a forprets device</p> <p>s₁₁- extraction of oil from the oil sludge using an extractor device</p> <p>s₁₂- refining of oil obtained by pressing</p> <p>s₁₃- transfer of extracted oil to the warehouse</p>
<i>c₄</i>	<p>s₁₄- oil packaging and delivery to the warehouse</p>

Materials and methods

The mathematical model of the information monitoring system is constructed using the Petri nets. The petri nets can be expressed as follows :

$$S = \langle P, T, E, \mu^0 \rangle, \quad (1)$$

in this, P – a set of final cases $P = \{p_1, p_2, \dots, p_m\}, m > 0$; T – the final set of transitions, $T = \{t_1, t_2, \dots, t_n\}, n > 0$;

E – the final set of bows, $E \subseteq P \times T \cup T \times P$, a set of arcs that lead from transition to transition and from transition to state;

μ^0 – initial marking, $\mu^0 : P \rightarrow N, N = \{0, 1, 2, \dots\}$.

$t_j \in T$ transition $I(t_j)$ unwanted, $O(t_j)$ outgoing cases and $p_j \in P$ of the situation $I(p_j)$ introduction, $O(p_j)$ represents the output transitions.

Materials and methods

If all the transitions are represented by a combination of the $I(t_j)$ and $O(t_j)$ $t_j \in T$ states of $I = \bigcup_T I(t_j), O = \bigcup_T O(t_j), P = I \cup O$, then from formula (1) the mathematical model of the information monitoring system of the oil and gas enterprise is represented by the following tuple:

$$S_{\text{model}} = \langle P_{\text{kol}}, I_{\text{jar}}, I_{\text{kir}}, O_{\text{chig}}, \mu^0, \mu' \rangle, \quad (2)$$

Here, $P_{\text{kol}} - S = \{s_0, s_1, \dots, s_{13}\}$ of raw materials in the process I_{kir} unwanted values $S^* = \{s_0^*, s_1^*, \dots, s_{m1}^*\}$ the database is stored in data structures I_{kir}^* represents the states of processes by values and is referred to as the state in the Petri nets.

$I_{\text{jar}} - S = \{s_0, s_1, \dots, s_{13}\}$ of raw materials in the process I_{kir} unwanted and O_{chig} executable on outgoing data $F^* = \{f_0, f_1, \dots, f_{n1}\}$ represents a set of features and is referred to as a transition in the Petri nets.

Materials and methods

I_{kir} – information monitoring system $S = \{s_0, s_1, \dots, s_{13}\}$ information entering the process. O_{chig} – from the information monitoring system $S = \{s_0, s_1, \dots, s_{13}\}$ process data.

In each process of the information monitoring system $S^* = \{s_0^*, s_1^*, \dots, s_{m1}^*\}$ data stored in tables $F^* = (f_{i1,j1})$, $i1 = \overline{0, m1}$, $j1 = \overline{0, n1}$ and is controlled by features. μ^0 – a marker indicating the status of the initial data in the manufacturing plant.

μ – a marker representing production norm data in processes.

The equations $P_{kol} = \{p_0, p_2, \dots, p_{19}\}$ and $T_{jor} = \{t_0, t_2, \dots, t_{13}\}$ were determined for the model of the information monitoring system from the production processes and product changes in the processes in the fat and oil enterprises.

The mathematical model of the information monitoring system and the graph using the detected P_{kol} cases and T_{jor} transitions are described as follows (Fig.2).

Materials and methods

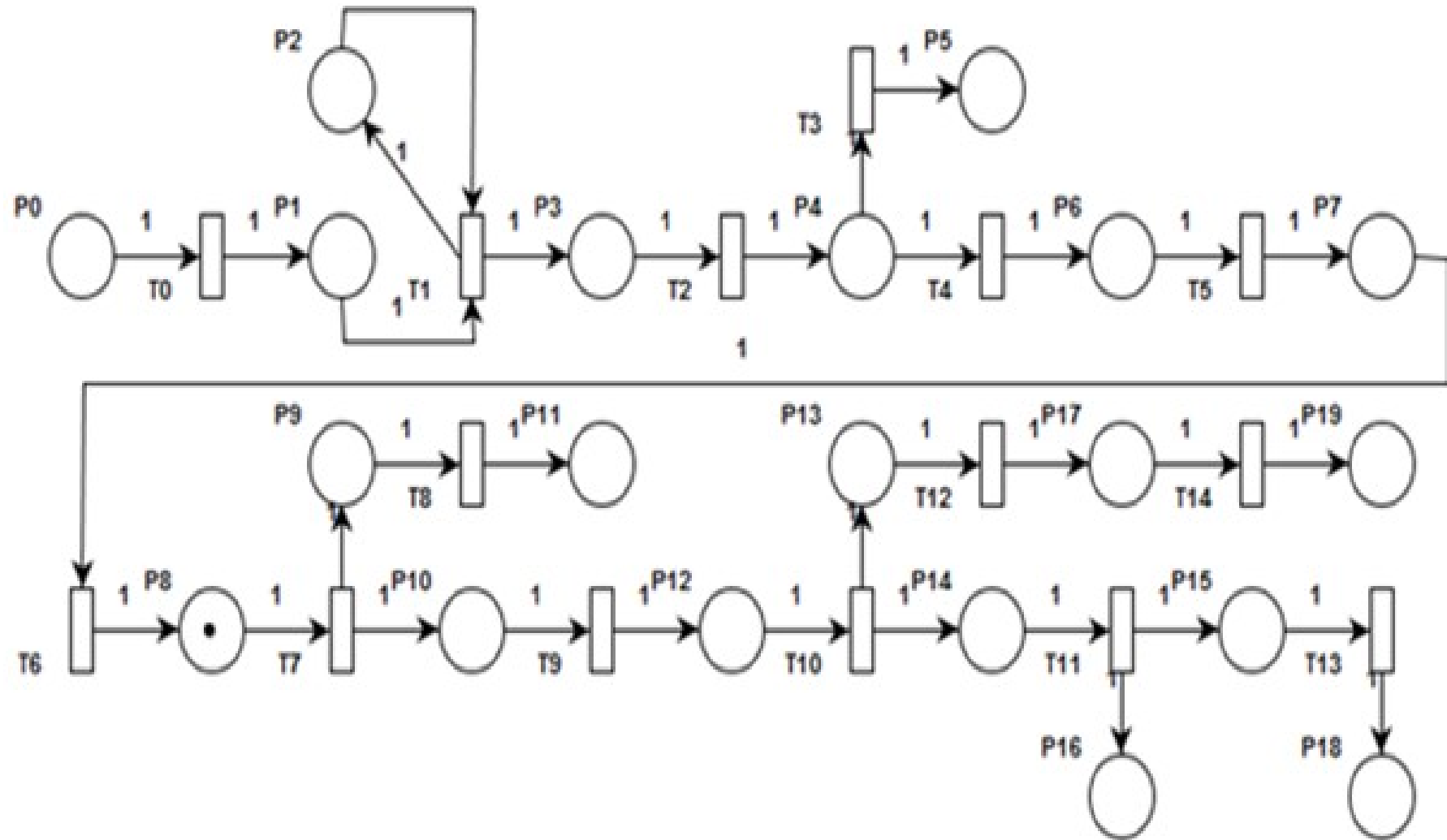

Fig.2. Graphical view of the mathematical model of the information monitoring system of the fat and oil enterprises

Materials and methods

As can be seen from Fig. 2, each $p_j \in P_{kol}$ is done by a $t_j \in T_{par}$ transition and the transition from one state to another. The model built on the Petri nets has a static appearance but the movement of the markers in the cases is dynamic and the monitoring process is done by changing the markers. Markers can also be represented in vector form:

$$N = \mu(P), \mu = \{\mu_0, \mu_1, \dots, \mu_n\}, \quad (3)$$

Here, $n = |P_{kol}|$ ба $\mu_i \in N$.

In the model represented by formula (2), the μ^r marking represents the resulting marking and the production norm. μ^p - marking initial marking, which represents the initial state of the production process. μ^p - the marking should reach merrrr based on the transition mechanism, i.e. it should be equal to $\mu^p = \mu^r$ after the production process is complete (Fig. 3).

Full field monitoring is accomplished through the movement of markers along a mathematical model in the Petri nets of an information monitoring system built for. The mechanism of change dynamics of markers in the model cases and the transition rule is realized through the functions in the database. The marker is marked with a thick dot inside a circle that reflects the situation on the graph.

Materials and methods

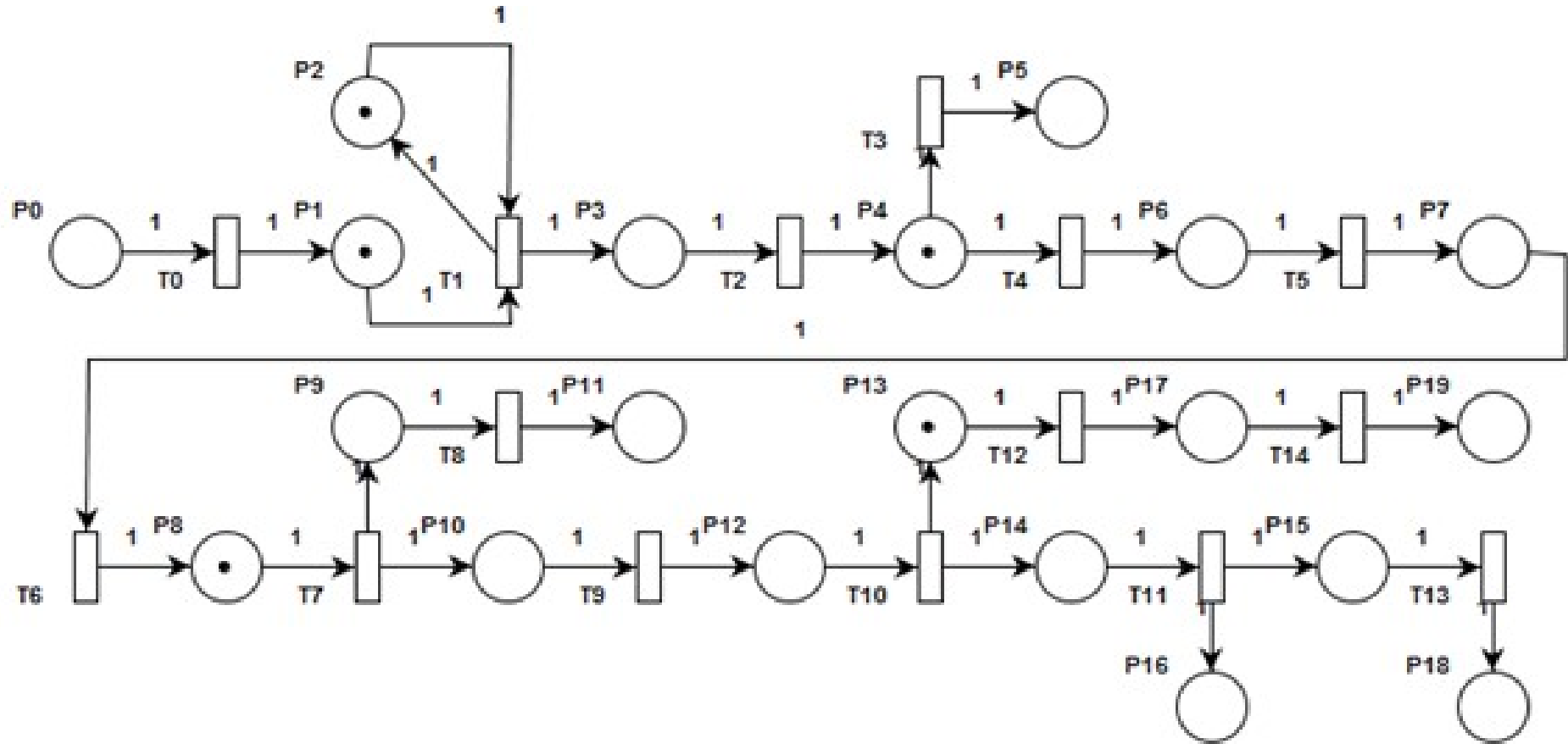

Fig. 3. Marked graph view of the mathematical model of the information monitoring system of the fat and oil enterprises

Results

The developed algorithm is applied in case of change of each marker. As a result, the model described in Figure 2 of the initial μ^0 markings included the initial $\mu_1^0 = 1$, $\mu_2^0 = 1$, $\mu_4^0 = 1$, $\mu_3^0 = 1$ and $\mu_{13}^0 = 1$ markings for the $P_{kol} = \{P_1, P_2, P_4, P_3, P_{13}\}$ cases. If the state of these markings satisfies the input state of the corresponding transition, then this production process is carried out and the information in this process is entered into the information monitoring system.

If the state of these markings satisfies the input state of the corresponding transition, then this production process is carried out and the information in this process is entered into the information monitoring system. The initial marking of the model is $\mu^0 = \{01101000100001000000\}$. In this case, the data on the process of achieving the final marking of the production norm μ^r are recorded in the system (Table 2).

In this case, the data on the process of achieving the final marking of the production norm μ^r are recorded in the system (Table 2). Processes in the enterprise are monitored through the data entered into the system during the movement of markers.

Results

Table 2. Initial and final markings

	P_0	P_1	P_2	P_3	P_4	P_5	P_6	P_7	P_8	P_9	P_{10}	P_{11}	P_{12}	P_{13}	P_{14}	P_{15}	P_{16}	P_{17}	P_{18}	P_{19}	
μ^0	0	1	1	0	1	0	0	0	1	0	0	0	0	1	0	0	0	0	0	0	0
μ^r	0	0	1	0	0	1	0	0	0	0	0	2	0	0	0	0	2	0	2	3	

The movement of the markers is done through the excited transitions.

In order for an excited $t_k \in T_{j \neq r}$ transition to occur, $I(t_k)$ must have at least one marker in the input tests ($\mu_s = \mu(p_s)$) for each transition and $p_s \in I(t_k)$ in each case) and markers equal to $\mu_s \geq 1$ and in the p_s state represents the number). The excited transition occurs after any t^* time and switches to single marker output states in all input states. This means that raw material data are recorded when the current production process is performed.

t_1 is given by $I(t_1) = \{p_1, p_2\}$ $o(t_1) = \{p_2, p_3\}$, $i(p_1) = 1$, $i(p_2) = 1$ and $o(p_2) = 1$, $o(p_3) = 0$, so that the excited transition is t_1^* transition.

After the t_1 transition has taken place, one of its input positions, a single marker is placed in the output position (to the right) (Fig. 3).

$$i^*(p_1) = 1 - 1 = 0, i^*(p_2) = 1 - 1 + 1 = 1, i^*(p_3) = 0 + 1 = 1.$$

Results

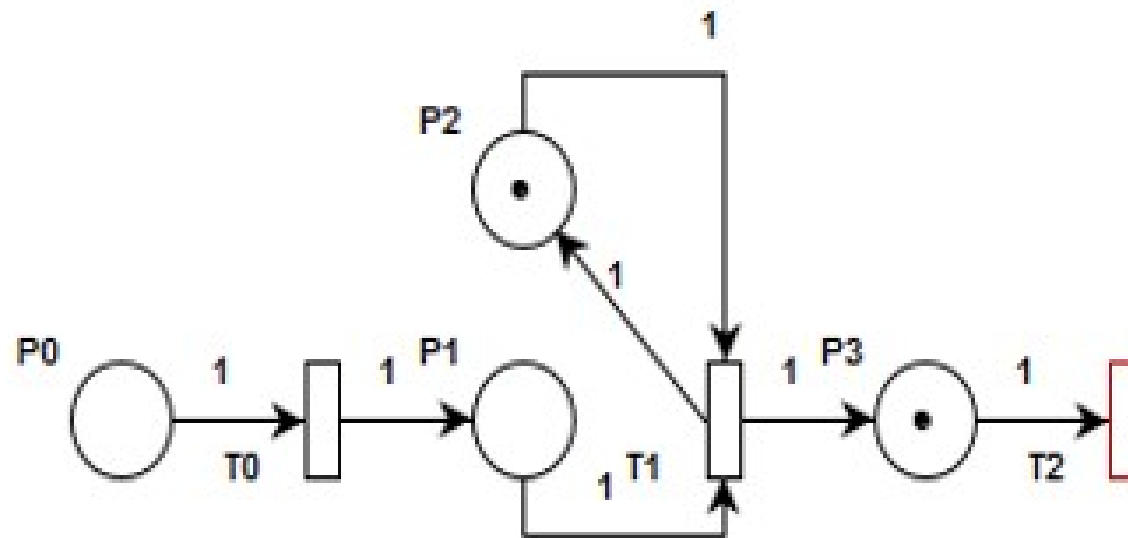

Fig3. t_1 is the change of markers in the excited transition

Here p_2 will be both input and output mode for switching t_1 . p_2 indicates the status of the quality laboratory and scales, and reflects the empty state after the analysis and measurement process has been performed. The marker in this case indicates that the laboratory is ready for analysis. From the movement of the markers, it can be seen that the transition t_1 indicates that the transition has been completed and the information in the information monitoring system has been entered in this transition. The transition t_1 refers to the input of the measured values of the quality laboratory and the electronic scales of the oily seed.

Results

Markers are formed by $F^* = (f_0, f_1, \dots, f_{m-1})$, functions developed on $S^* = \{s_0^*, s_1^*, \dots, s_{m-1}^*\}$ data structures in the database. For example,

- The marker in p_3 represents the type, moisture and quantity, weight, gross, date of receipt, type of product and other information received after analysis in the laboratory, the product is stored in the $\in S^*$ tables `h_ins_m`, `h_ins_m2` queries. If these processes are fully implemented, a marker is generated in the case in the model.

An algorithm for monitoring the status of production processes through marker-driven transitions is proposed as follows.

1-step. The date or interval to be monitored by the user is entered.

2-step. For each production process $\mu^r = \{\mu_0^0, \mu_0^1, \dots, \mu_0^{19}\}$ in the database

`h_sel_holat` $\in F^*$ the norm of production in all processes through the function `Plresult[20]` separated into an array.

Results

3-step. In every production process $\mu = \{\mu^0, \mu^1, \dots, \mu^{19}\}$ current cases $F^{**} = \{h_sel_0^i, f_1^i, \dots, f_k^i\} \subseteq F^*$ using features $Jl_{result}[20]$ separated into an array.

4-step. $P1_{result}$ and Jl_{result} the values of the arrays in the corresponding indices are compared and the values obtained without the result and the resulting values are stored in $Ml_{notresult}$ arrays.

5-step. Using the values of the Ml_{result} array, each production process stops working if it achieves a result, otherwise it is moved to the next step.

6-step. $Ml_{notresult}$ the elements in the array represent unsuccessful processes and allow the identification of unsuccessful processes.

7-step. Cases of processes that have achieved and have not $C = \{c_0, c_1, \dots, c_4\}$ цехлар кесимида $C = \{c_0^*, c_1, \dots, c_4\}$ divided into groups.

8-step. Unfinished processes are presented at the intersection of production shops.

9-step. The algorithm terminates.

Discussion and Conclusions

Since the production process at the fat and oil enterprises in the form of a conveyor belt, a mathematical model of the information monitoring system was built through the Petri nets. Each production process is tracked through situation and processes in the Petri nets. All data is recorded in the software. Based on this information, the production process is monitored.